

DHB

Panel mounted digital instruments



Description

Panel mounted digital devices designed to display on-screen the value of a electrical variable measured or proportional value of a process signal, depending on the model. Essential for regulation purposes, programming the analogue output available in some models, and for control purposes, if the relay outputs are used as alarms.

DHB units are fully programmable and the following can be programmed: scale, transformation ratios, alarm setpoints to activate relays, communications, colour of the numbers displayed on screen, etc. Depending on the model, you can measure the electrical parameters of a single-phase installation such as voltage, current, frequency, power, $\cos \varphi$, etc., the direct voltage or current of an installation, impulses, frequency, circular speed, periods, time, temperature and also other voltage and current process variables. AC models calculate the true root mean square measure (TRMS).

The models include the following common features:

- IP 65 front panel
- High measurement accuracy
- Programmable measurement input
- Delay and latching alarms
- 24 Vdc output for supply external transducers (**DHB 1xx** and **DHB 4xx** models)
- Galvanic insulation between external circuits
- Adjustment of non-linear equations with 21 straight points (2 in the **DHB 3xx** model).
- Change in colour of the display depending on the value shown.
- Maximum and minimum values
- Clock with current time
- Self-configurable decimal point
- Compatible with **Power Studio***
- Installation on 96 x 48 mm panel

Technical features

Power supply	Power supply voltage	85...253 Vac / 85...253 Vdc
	Optional (DHB 2xx, 4xx) (20...60 Vdc)	20...40 Vac / 20...40 Vdc
Inputs	No. of inputs	Depending on the model
Relay outputs	No. of outputs	2
	Type	(NO) relay
	Load capacity	250 Vac / 5 Aac
Analogue outputs*	No. of outputs	1
	Type	Programmable 0/4...20 mA Programmable 0...10 V*
Transistor outputs*	Load resistor	$\leq 500 \Omega$ $\geq 500 \Omega$
	No. of outputs	1
Display	Type	NPN Transistor with open collector
	Electrical features	30 Vdc / 30 mA
	No. of digits	5 digits
	Indication limits	-19999...99999
	Digit height	14 mm
Communications*	Colour	Red, orange and green (according to the value)
	Medium / Protocol	RS-485 / Modbus/RTU
Build features	Protection degree	IP 65 (front panel) IP 10 (rear)
	Weight	< 0.2 kg
Environmental conditions	Temperature	-25...+55 °C
	Relative humidity	25...95% (without condensation)
	Maximum altitude	2,000 m
Safety	Designed for CAT III 300/520 Vac installations, in accordance with EN 61010 . Double-insulated electric shock protection, class II	
Standards	EN 61000-6-2, EN 61000-6-4	

* Model with communications

Panel mounted digital instruments

Applications

These digital instruments have multiple applications. Thanks to their very bright 5-digit and 3-colour screen, you can simply view a numerical value and an alarm or prealarm status of a measured variable. Depending on the model selected, displayed on-screen are the electrical parameters of a single-phase installation as a power analyzer (voltage, current, power, frequency, etc.).

Other models allow to visualize the value of an analogue signal, show impulses received through an input, temperature, time, circular speed and many other variables that depends on the device and the configuration. The indicators also let you operate any external element, using the panel unit outputs as alarms depending on the value of a variable or as a transducer of the measured variable to an analogue signal, which is subsequently sent to another unit, such as a PLC.

Apart from displaying the values, units with communications also allow you to send data via the RS-485 communication bus for software or PLC integration.

References

Variables	Outputs	Power supply	Type	Code
Impulses, frequency, circular speed, periods, time, <i>encoder</i>	1 relays	85... 253 V _{ac/dc} 20...40 V _{ac/dc}	DHB-102	M22021 M22021001000
	3 relays + 1 analogue + RS-485	85... 253 V _{ac/dc} 20...40 V _{ac/dc}	DHB-124	M22022 M2202210000
	2 relays	85... 253 V _{ac/dc} 20...40 V _{ac} 20...60 V _{dc}	DHB-202	M22023 M220230020000
	4 relays + 1 analogue + RS-485	85... 253 V _{ac/dc} 20...40 V _{ac} 20...60 V _{dc}	DHB-224	M22024 M220240020000
Voltmeter or ammeter ± 100...500 V _{dc} ± 1...5 A _{dc}	2 relays	85... 253 V _{ac/dc} 20...40 V _{ac} 20...60 V _{dc}	DHB-302	M22025 M220250010000
	4 relays + 1 analogue + RS-485	85... 253 V _{ac/dc} 20...40 V _{ac} 20...60 V _{dc}	DHB-324	M22026 M220260010000
	2 relays	85... 253 V _{ac/dc} 20...40 V _{ac} 20...60 V _{dc}	DHB-402	M22027 M220270020000
	4 relays + 1 analogue + RS-485	85... 253 V _{ac/dc} 20...40 V _{ac} 20...60 V _{dc}	DHB-424	M22028 M220280020000
Pt100/500/1000 Thermocouple J, K, N, E, R, S, ± 20 mA, ± 10 V, 60 mV	2 relays	85... 253 V _{ac/dc} 20...40 V _{ac} 20...60 V _{dc}	DHB-402	M22027 M220270020000
	4 relays + 1 analogue + RS-485	85... 253 V _{ac/dc} 20...40 V _{ac} 20...60 V _{dc}	DHB-424	M22028 M220280020000

Dimensions

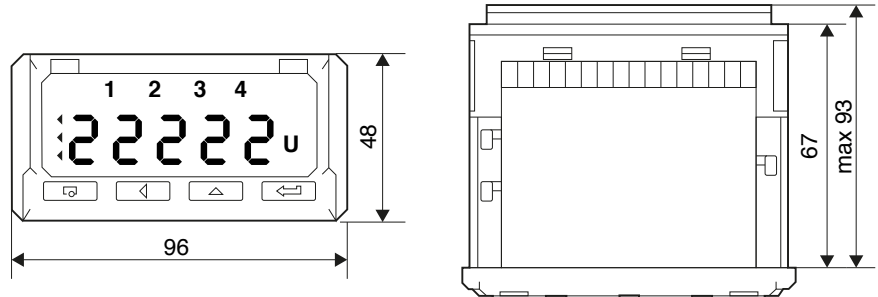

DHB-102/124

Impulse, frequency and time meter



Description

Digital panel device designed to display on-screen, and depending on the configuration, the values of impulses, frequency, time, circular speed, periods, encoder, etc.

The specific features of these models are:

- Measurement of number of impulses, frequency, circular speed, working time.
- 2 impulse meters, compatible with encoders.
- Instantaneous and incremental values meter.
- 4 outputs* available for alarms with LED indication.
- Conversion of any value measured to 0(4)...20 mA or 0...10 V analogue signal.
- Storage of maximum and minimum values of all parameters measured.
- Auxiliary power supply for transducers.
- Adjustment of non-linear equations with 21 straight points.
- Modbus/RS-485 communications.*

* According to model.

Technical features

Consumption	1.2...9.0 VA	1.2... 6.0 W
Inputs	No. of inputs	1
	Type	Digital for impulses 5...36 Vdc
	Functions of the inputs	<ul style="list-style-type: none"> - Impulse meter - Frequency meter - Circular speed meter - Time period - Operating hours meter - Encoder
Measurement variables	IN1 / IN2 impulse meter	-19999...+99999
	Frequency < 10 kHz	0.05...+100 kHz
	Frequency > 10 kHz	1...+100 kHz
	Circular speed	0.05...99999 rpm
	Period t < 10 s	0.0001...11 s
	Period t > 10 s	0.0001...3600 s
	Working time meter	0...99999 h
	Encoder	-19999...99999

References

Variables	Outputs	Power supply	Type	Code
Impulses, frequency, circular speed, periods, time, encoder	1 relays	85... 253 V _{ac/dc}	DHB-102	M22021
		20...40 V _{ac/dc}		M22021001000
	3 relays + 1 analogue + RS-485	85... 253 V _{ac/dc}	DHB-124	M22022
		20...40 V _{ac/dc}		M2202210000

Connections

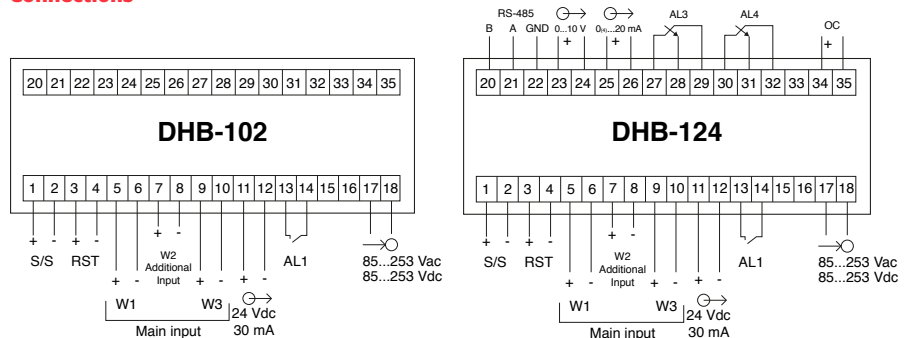

DHB-202/224

DC voltmeter or ammeter



Description

Digital panel device designed to display on-screen, and depending on the configuration, the measured current or voltage values.

- The specific features of these models are:
- Current or voltage measurement up to 5 A_{dc} or 500 V_{dc}.
- 4 outputs* available for alarm with LED indication.
- Conversion of any value measured to 0(4)...20 mA or 0...10 V analogue signal.
- Storage of maximum and minimum values of all parameters measured.
- Auxiliary power supply for transducers.
- Adjustment of non-linear equations with 21 straight points.
- Modbus/RS-485 communications.*

* According to model.

Technical features

Consumption	2.1...9.5 VA	2.1... 5.5 W
Inputs	No. of inputs	1
	Type	DC measurement
	Functions of the inputs	– Current input – Voltage input
Measurement variables	Input ± 500 V _{dc}	-600...+600 V _{dc} max
	Input ± 100 V _{dc}	-130...+130 V _{dc} max
	Input ± 5 A _{dc}	-6...+6 A _{dc} max
	Input ± 1 A _{dc}	-1.2...+1.2 V _{dc} max

References

Variables	Outputs	Power supply	Type	Code
Voltmeter or ammeter ± 100...500 V _{dc} ± 1...5 A _{dc}	2 relays	85... 253 V _{ac/dc}	DHB-202	M22023
		20...40 V _{ac} 20...60 V _{dc}		M220230020000
	4 relays + 1 analogue + RS-485	85... 253 V _{ac/dc}	DHB-224	M22024
		20...40 V _{ac} 20...60 V _{dc}		M220240020000

Connections

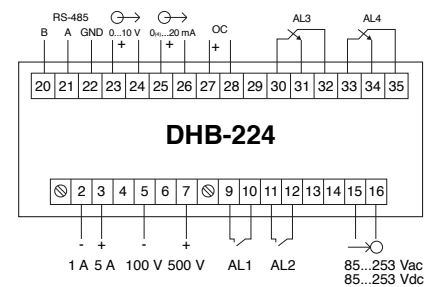
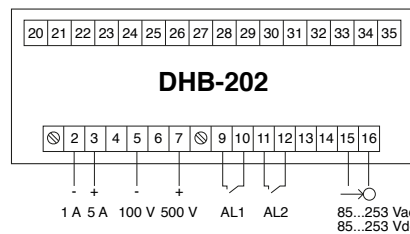

DHB-302/324

AC single-phase multimeter



Description

Digital panel device designed for single-phase measurement of: voltage, current, active, reactive and apparent power, $\cos \phi$, $\text{tg } \phi$, ϕ , frequency, active, reactive and apparent energy.

The specific features of these models are:

- 4 outputs* available for alarms with LED indication.
- Conversion of any value measured to 0(4)...20 mA or 0...10 V analogue signal.
- Storage of maximum and minimum values of all parameters measured.
- Modbus/RS-485 communications.*

* According to model.

Technical features

Consumption	1.3...5.9 VA	1.3... 3.7 W
Inputs	No. of inputs	1
	Type	AC measurement
	Functions of the inputs	<ul style="list-style-type: none"> – Voltage – Current – Active, reactive and apparent power – $\cos \phi$, $\text{tg } \phi$, ϕ – Frequency – Active, reactive and apparent energy
Measurement variables	Current .../1 A or .../5 A	0...60 kA
	Voltage 100 V / 400 V	0... 192 MV
	Frequency	45...100 Hz
	Active power	-19999...+99999 MW
	Reactive power	-19999...+99999 Mvar
	Apparent power	0...+99999 MVA
	$\cos \phi$	-1...+1
	Tangent ϕ	-1.2...+1.2
	ϕ	0...359
	Active energy	0...9999999.9 kWh
	Apparent energy	0...9999999.9 kVarh
	Reactive energy	0...9999999.9 kVA

References

Variables	Outputs	Power supply	Type	Code
Single-phase analyzer $\pm 100/400 \text{ V}_{ac}$ $\pm 1/5 \text{ A}_{ac}$	2 relays	85... 253 $\text{V}_{ac/dc}$	DHB-302	M22025
		20...40 $\text{V}_{ac/dc}$		M220250010000
	4 relays + 1 analogue + RS-485	85... 253 $\text{V}_{ac/dc}$	DHB-324	M22026
		20...40 $\text{V}_{ac/dc}$		M220260010000

Connections

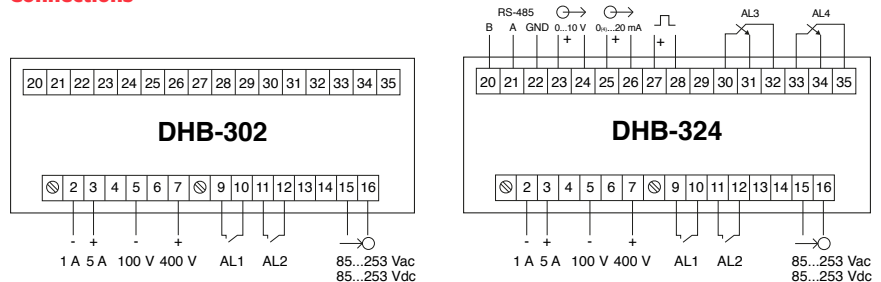

DHB-402/424

Signal process, temperature and resistance indicator



Description

Digital panel device designed to display on-screen, and depending on the configuration, the measured process, temperature and resistor signal values.

The specific features of these models are:

- 4 outputs connected to the alarm with LED indication that work in 6 different modes.
- Conversion of any value measured to 0/4)...20 mA or 0...10 V analogue signal.
- Storage of maximum and minimum values of all parameters measured.
- Auxiliary power supply for transducers.
- Adjustment of non-linear equations with 21 straight points.
- Modbus/RS-485 communications.*

* According to model.

Technical features

Consumption	1.3...6.5 VA	1.3... 3.7 W
Inputs	No. of inputs	1
	Type	Analogue (Pt100, Pt500, Pt1000, Termocouple, 20 mA, 60 mV or 10 V)
	Functions of the inputs	<ul style="list-style-type: none"> – Temperature measurement – Process signal measurement – Resistor measurement
Measurement variables	Temperature (Pt100 probe)	
	Temperature (Pt500 probe)	-205...+855 °C (-200...850 °C)
	Temperature (Pt1000 probe)	
	400 Ω	0...410 Ω (0...400 Ω)
	4000 Ω	0...4010 Ω (0...4000 Ω)
	Type J thermocouple	-200...+1200 °C (-100...+200 °C)
	Type K thermocouple	-200...+1370 °C (-100...+1370 °C)
	Type N thermocouple	-200...+1300 °C (-100...+1300 °C)
	Type E thermocouple	-200...+1000 °C (-100...+1000 °C)
	Type R thermocouple	-50...+1768 °C (-50...+1760 °C)
	Type S thermocouple	-50...+1768 °C (-50...+1760 °C)
	Voltage input 0...+10 V	-13...+13 V (-10...+10 V)
	Current input	-24...+24 mA (-20...+20 mA)
Voltage input	-10...+63 mV (0...+60 mV)	

References

Variables	Outputs	Power supply	Type	Code
Process, temperature and resistor signal indicator 0/4...20 mA, 60 mV, 0...10 V _{dc}	2 relays	85... 253 V _{ac/dc}	DHB-402	M22027
		20...40 V _{ac} 20...60 V _{dc}		M220270020000
	4 relays + 1 analogue + RS-485	85... 253 V _{ac/dc}	DHB-424	M22028
		20...40 V _{ac} 20...60 V _{dc}		M220280020000

Connections

